

MARKS:
 SAC: 1.019-1.131
 ACSR: 795 24/7 26/7 45/7 54/7
 666.6 30/19 954 36/1 636 30/19
 ACSRTW & SD: 762.8 T16 795 T16
 USE CORE GRIP WITH ACSR
 DIE SIZE: 12CD
 60 TON PRESS MIN.
 [CURRENT DATE] FARGO
 UNI-GRIP, PSAB0112

MARKS:
 SAC: 1.026-1.131
 COMP/TW: 0.960-1.010
 DIE SIZE: 12CD
 60 TON PRESS MIN.
 [CURRENT DATE] FARGO
 UNI-GRIP, PSJTF12

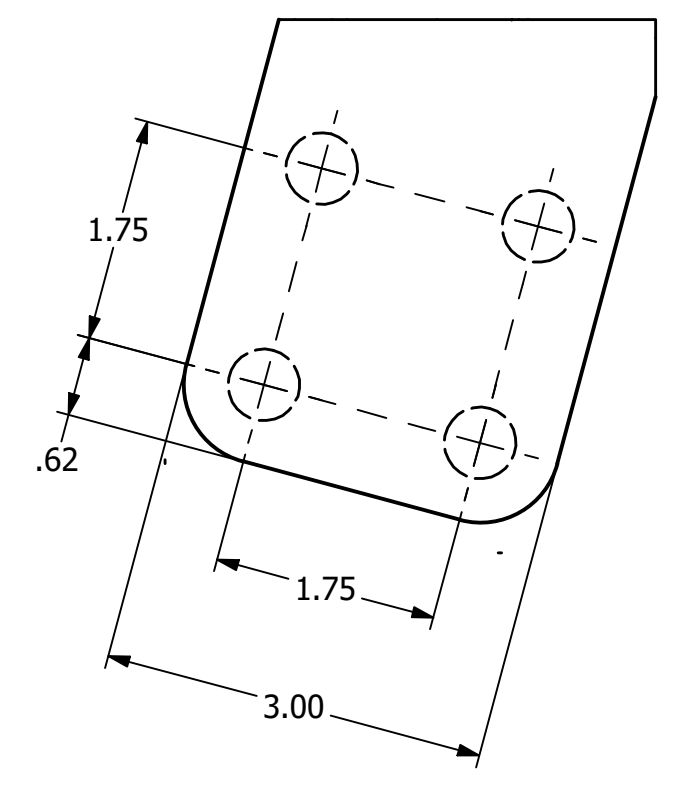

- NOTES:
1. MATERIAL: DEADEND BODY, TERMINAL AND HARDWARE - ALUMINUM ALLOY
STEEL EYE - GALV. STEEL
 2. DEADEND AND TERMINAL PREFILLED WITH FARGO JOINT COMPOUND TYPE UJC.
 3. TAPERS AND PAD PROTECTED WITH PLASTIC MESH.
 4. CORE GRIP INCLUDED IS MARKED "FARGO 45".
 5. HARDWARE INCLUDED: FOUR 1/2-13 AL. BOLTS & NUTS, EIGHT AL. WASHERS.
 6. DIMENSION IN INCHES.
 7. SHIP UNASSEMBLED.
 8. ULTIMATE STRENGTH - FULL TENSION.

--	--	--	TM	PTB
EC #	DATE	CHANGED BY	CHECKED BY	APPROVED BY
DESCRIPTION: DRAWING CREATED IN INVENTOR				WEIGHT, LBS 6.67
<div style="border: 1px solid black; border-radius: 10px; padding: 5px; text-align: center; color: red; font-weight: bold;">PRELIMINARY</div>				THIRD ANGLE PROJECTION
				<small>CONFIDENTIAL: THIS DRAWING AND ITS CONTENTS ARE CONFIDENTIAL AND THE EXCLUSIVE PROPERTY OF HUBBELL POWER SYSTEMS. NO PUBLICATION, DISTRIBUTION OR COPIES MAY BE MADE WITHOUT THE WRITTEN CONSENT OF HUBBELL POWER SYSTEMS. HUBBELL POWER SYSTEMS UNPUBLISHED ALL RIGHTS RESERVED UNDER THE COPYRIGHT LAWS</small>
ADDITIONAL COMMENTS: --				

HUBBELL POWER SYSTEMS, Inc.			
TITLE		UNI-GRIP COMPRESSION DEADEND ASSEMBLY	
CATALOG NUMBER: A0112451			
SIZE C	DWG NO. CUTSHEET	PART / ASSY NO. --	REV A
SCALE: NS	DRN BY: RR	DATE: 08/28/23	SHEET 1 OF 1